

Tank Water Level Gauge

Two pieces of 1.5" PVC pipe sawn lengthwise enough off center so that the two larger halves retain the full diameter when put together (compensating for the width of the saw cut).

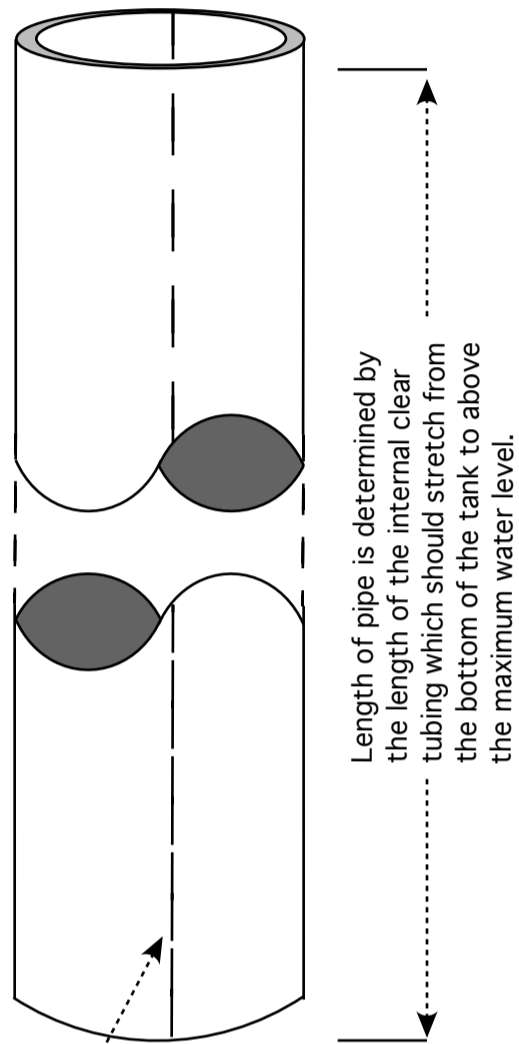

Cut here slightly off center (a few trial cuts likely to be required).

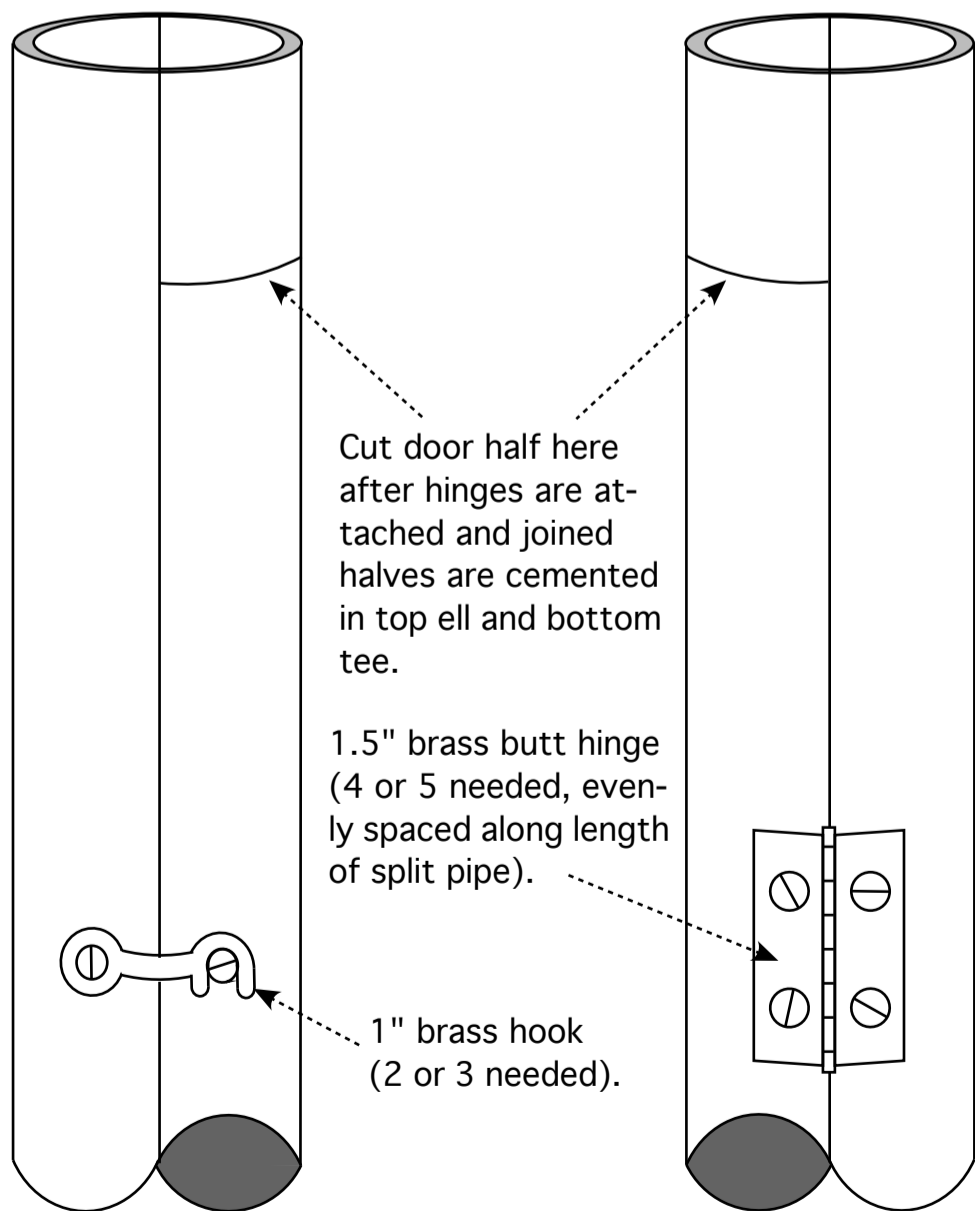

Cut door half here after hinges are attached and joined halves are cemented in top ell and bottom tee.

1.5" brass butt hinge (4 or 5 needed, evenly spaced along length of split pipe).

1" brass hook (2 or 3 needed).

